

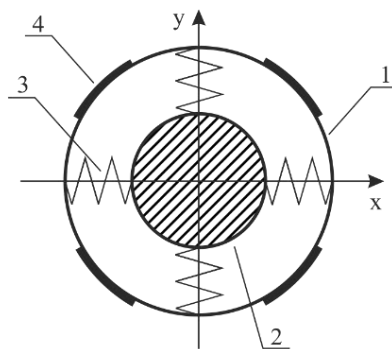

Localization of acoustic emission sources according to the data of a distributed system of combined receivers

SHCHERBINA A.O., SOLODCHUK A.A., VASKIN V.A.,
TORGONSKYI V.E.

ACOUSTIC SIGNAL RECORDING

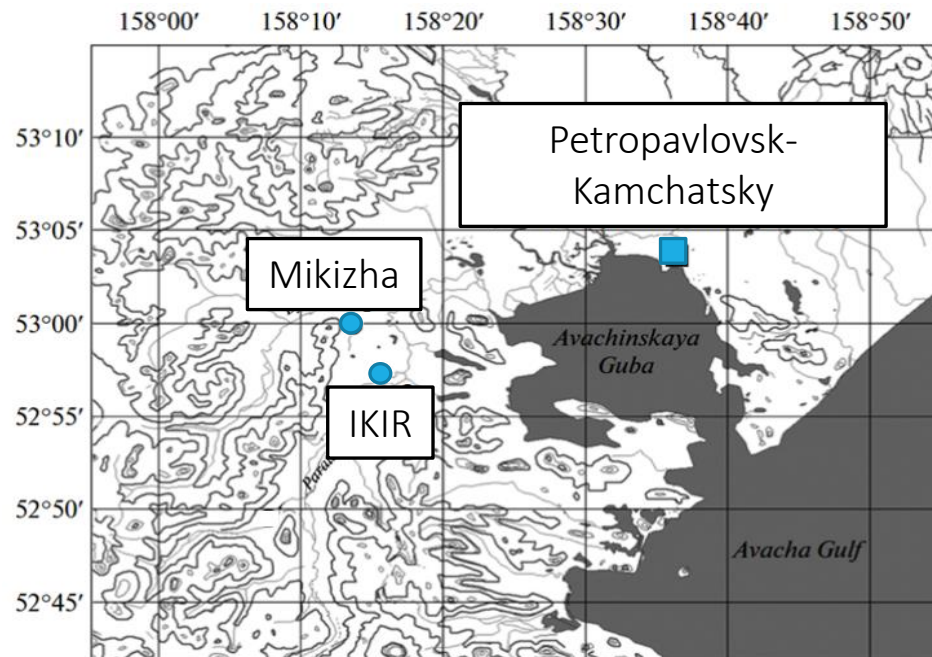

- 1 – receiver body,
- 2 – inertial mass,
- 3 – elastic elements,
- 4 – pressure receiver components

Measured values: P , ∇P_x , ∇P_y , ∇P_z
Frequency range: 100 Hz – 10 kHz

REGISTRATION SYSTEM

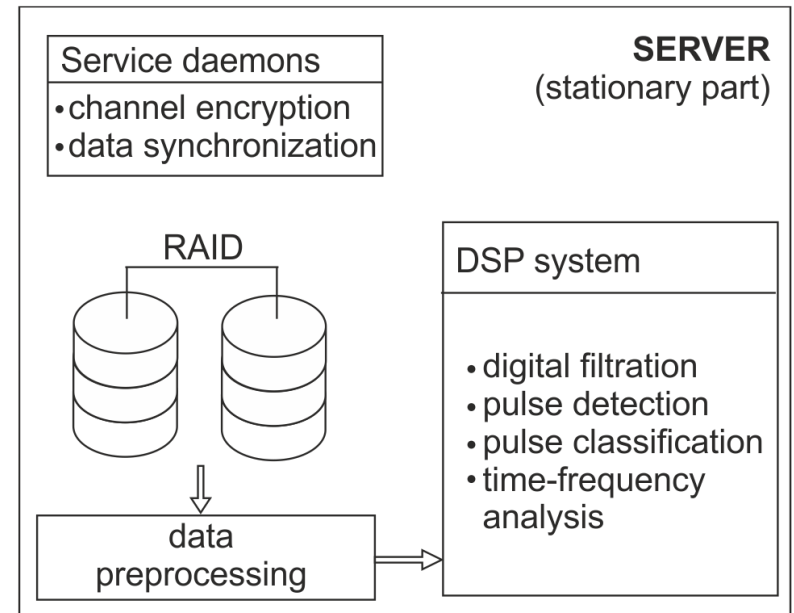
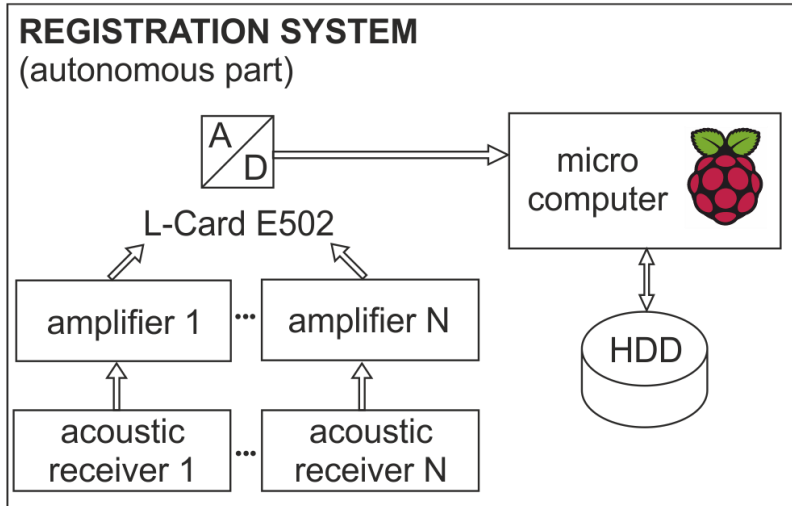
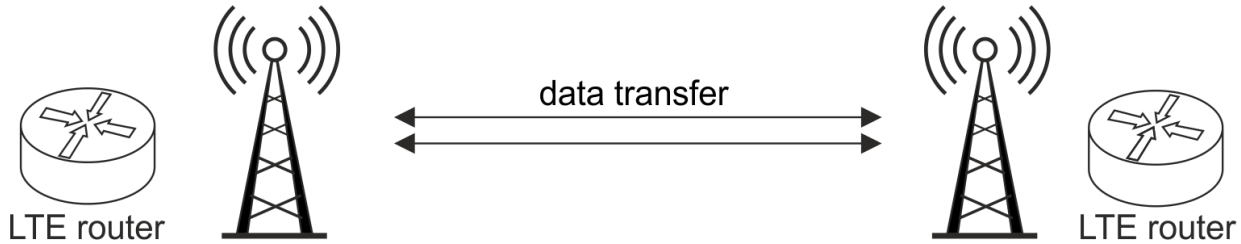

RECEIVER LOCATION DIAGRAM (February 13, 2023)

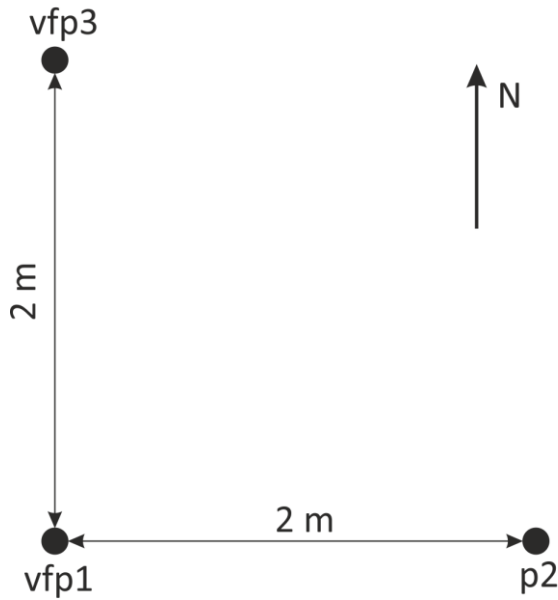

Overhead view

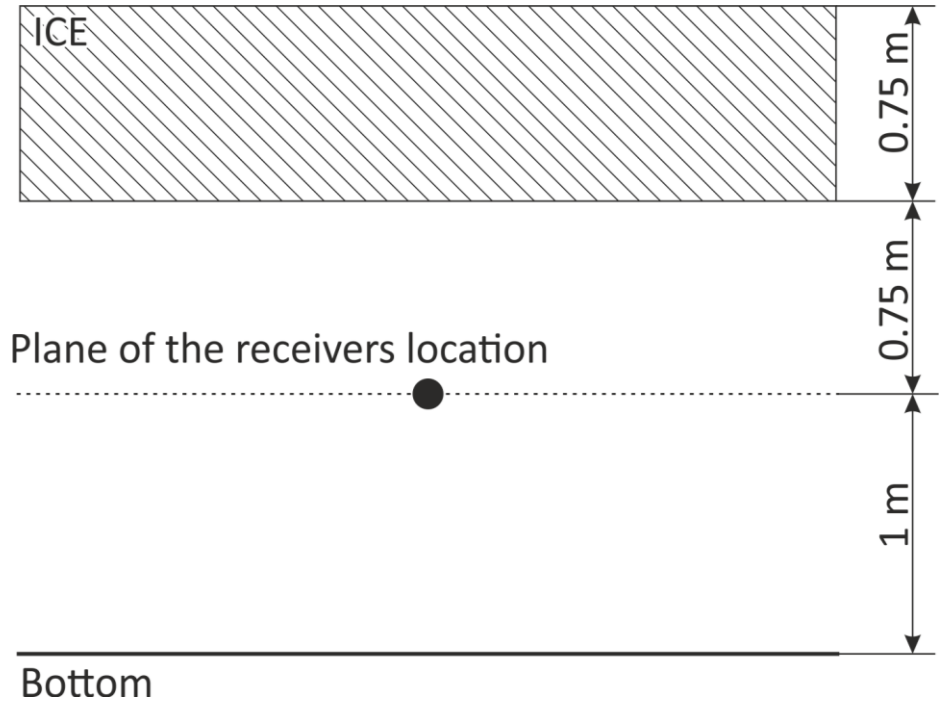

View in vertical section

ACOUSTIC EMISSION SIGNAL

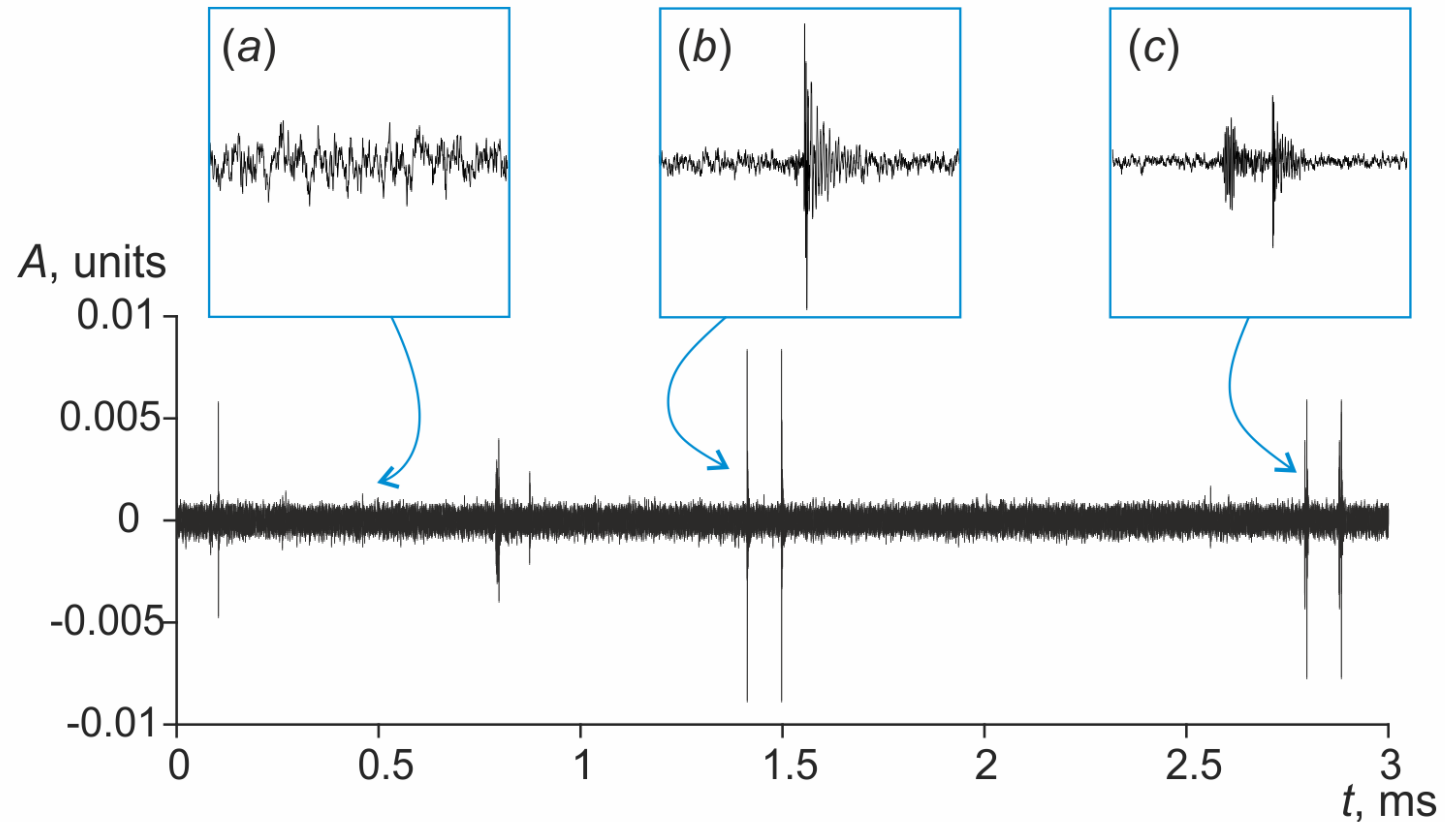

Acoustic emission signal fragment: (a) – noise; (b), (c) – pulses.

ACOUSTIC PULSE

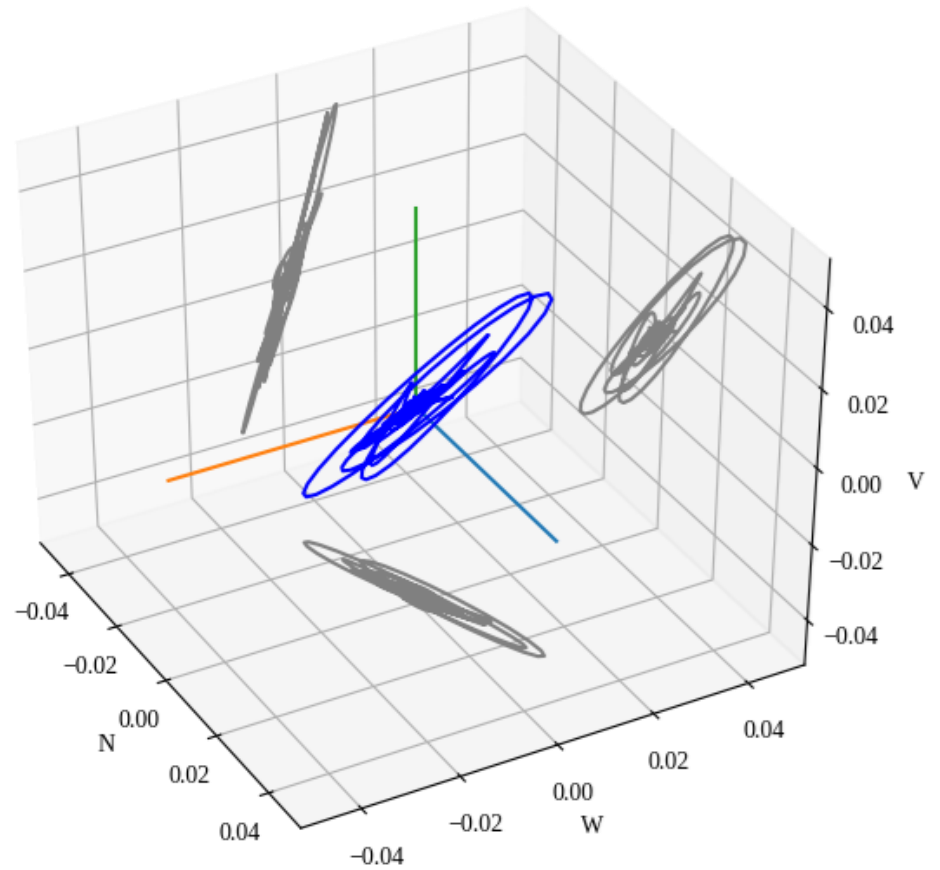
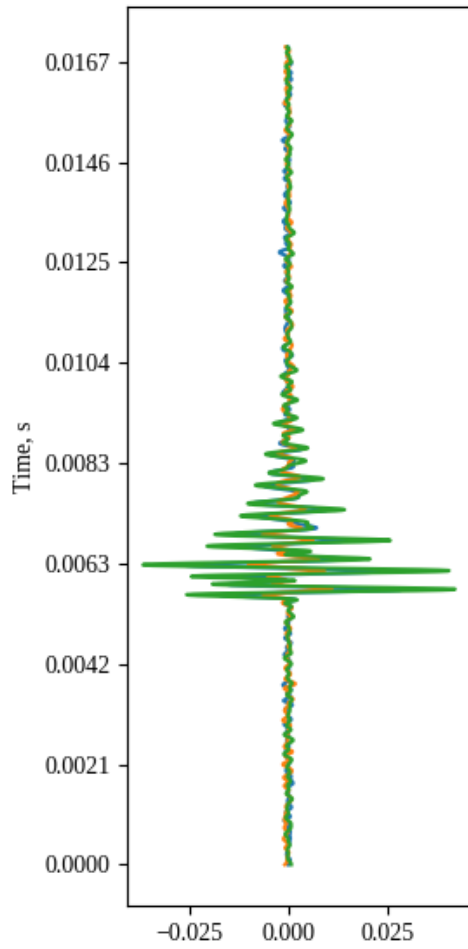

LOCALIZATION METHODS

Triangulation

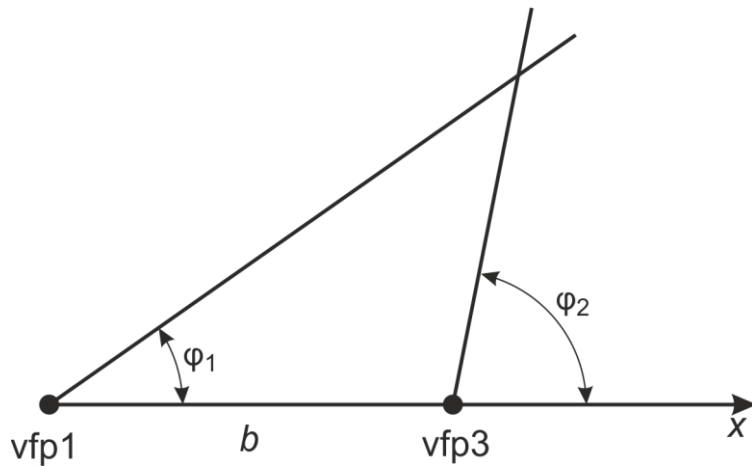

Time delay

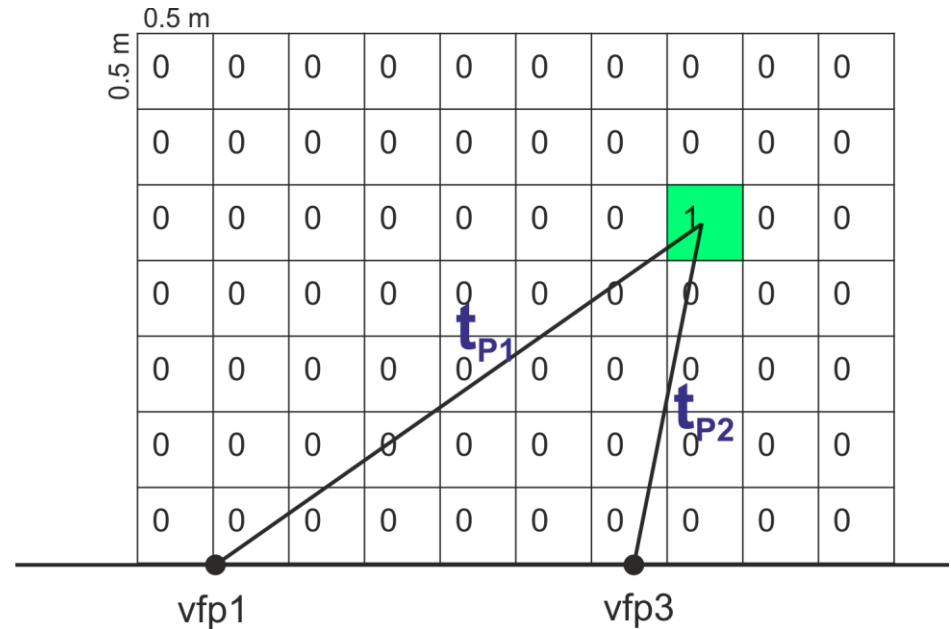

$$1 : \text{if } \Delta t_p - \Delta t_s < t_{\text{err}}$$

Δt_p - calculated signal delay,

Δt_s - measured signal delay,

t_{err} - permissible error (corresponds to the time during which the wave propagates 0.25 m)

VFP1

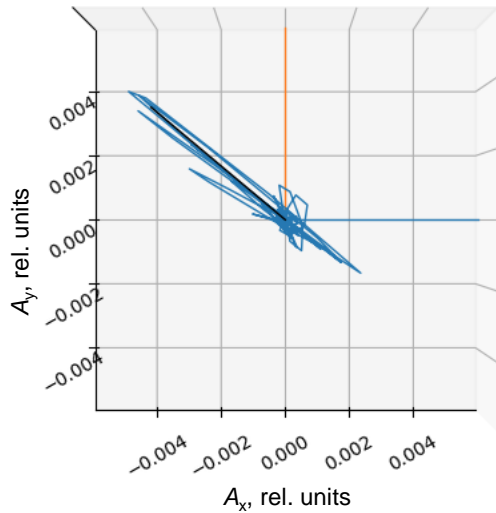
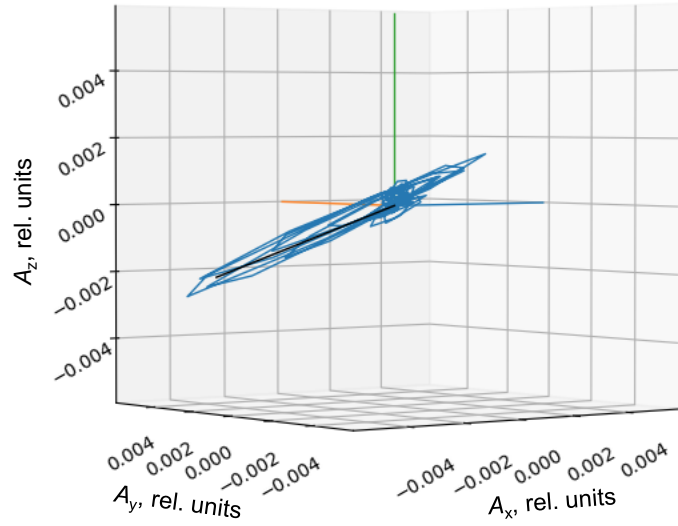
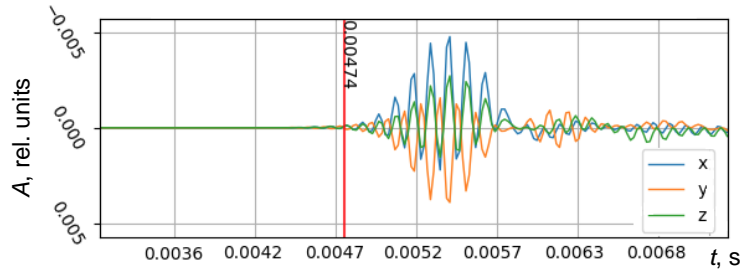

VFP3

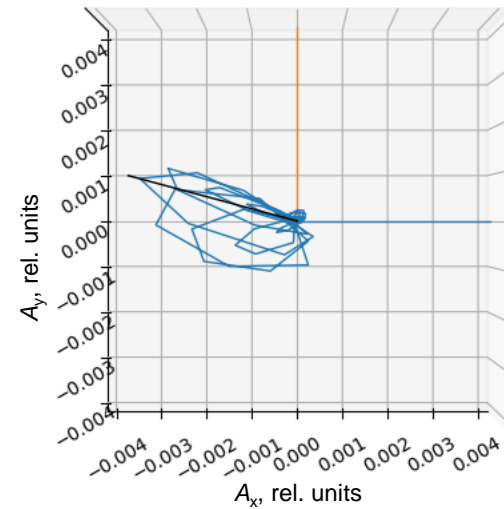
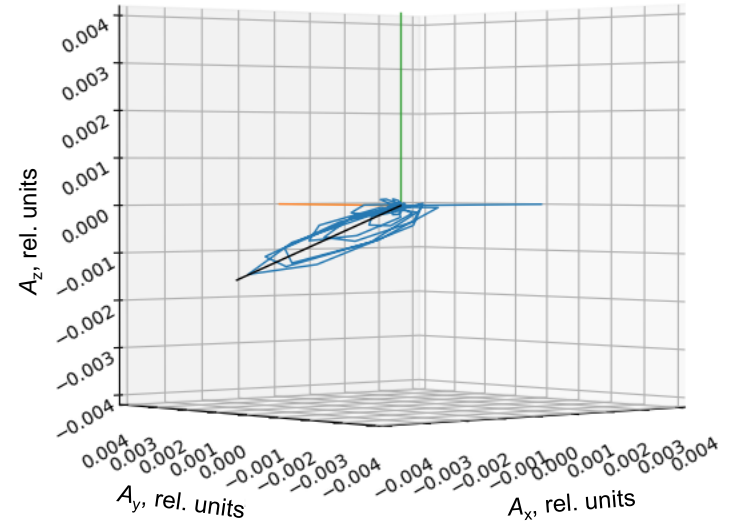
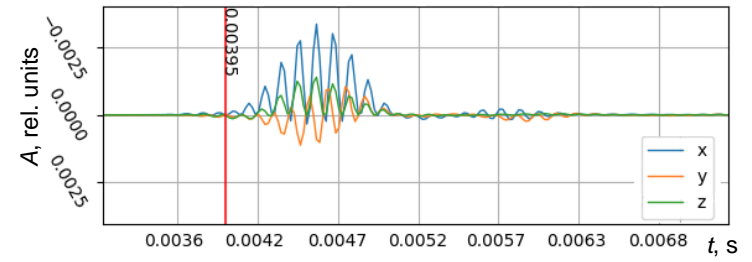

PULSE 1

LOCALIZATION RESULT

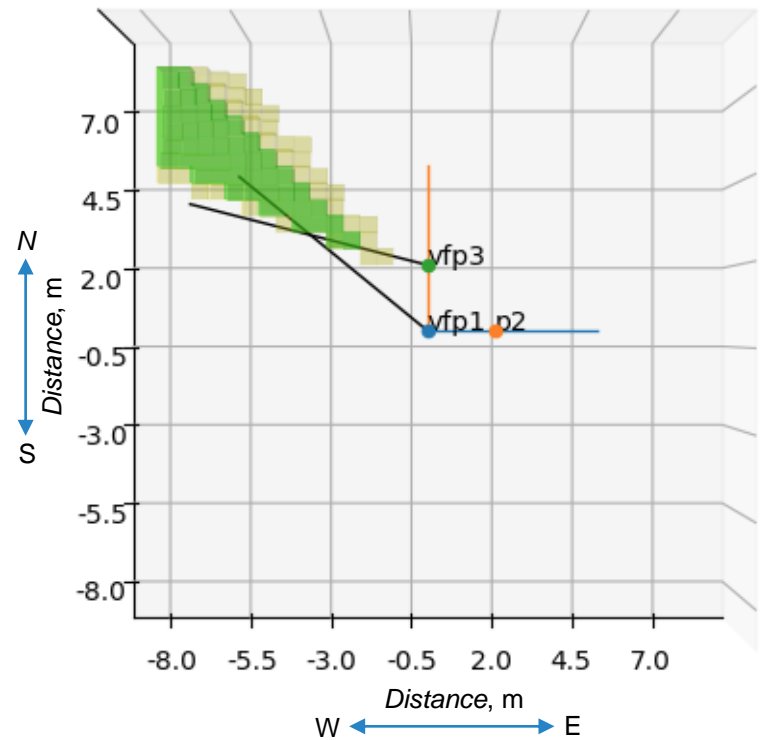
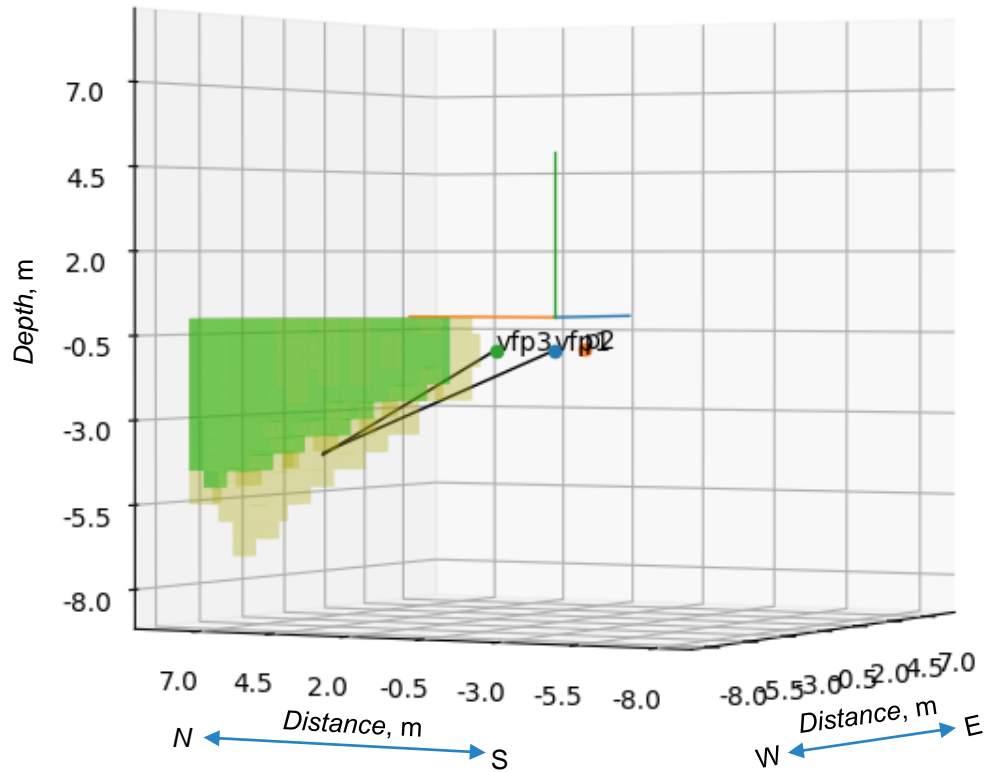

VFP1

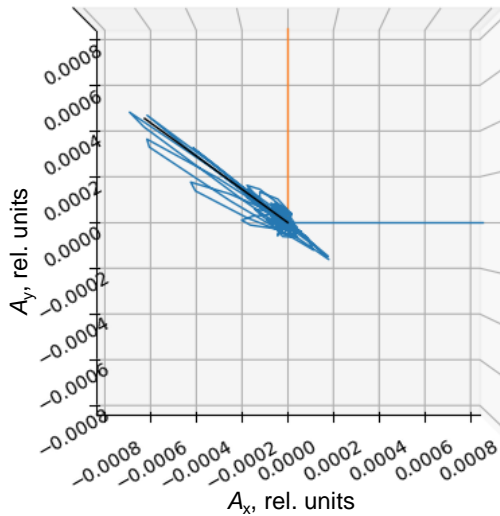
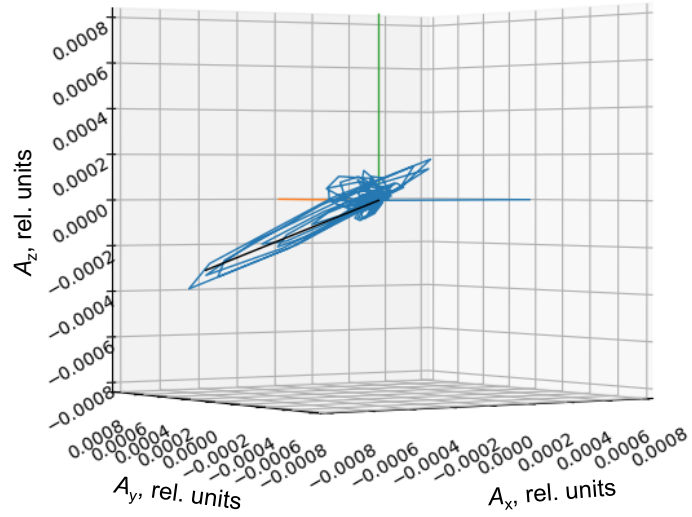
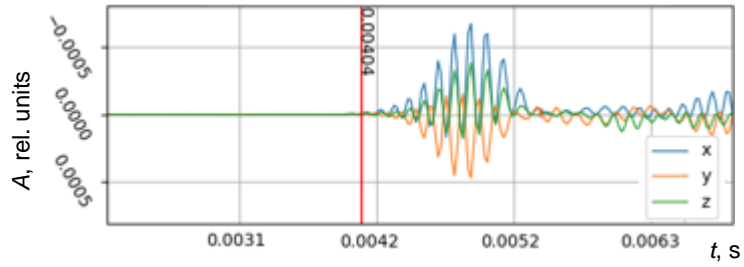

VFP3

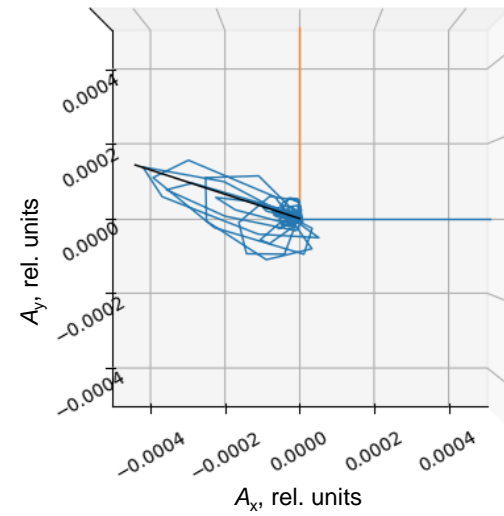
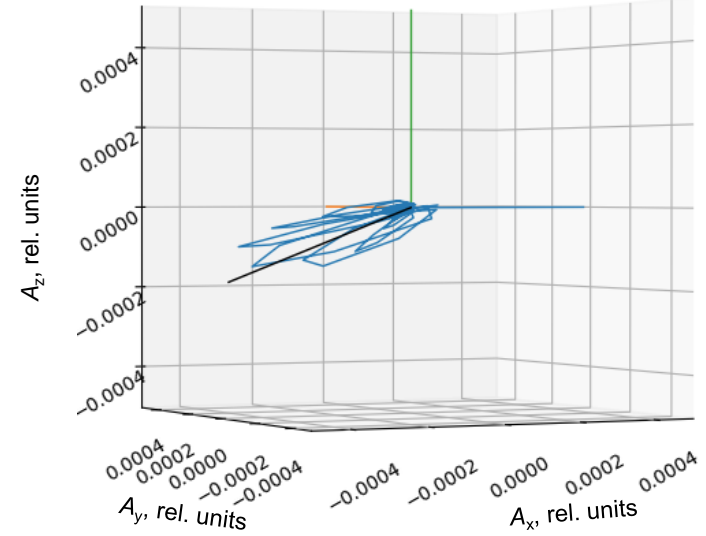
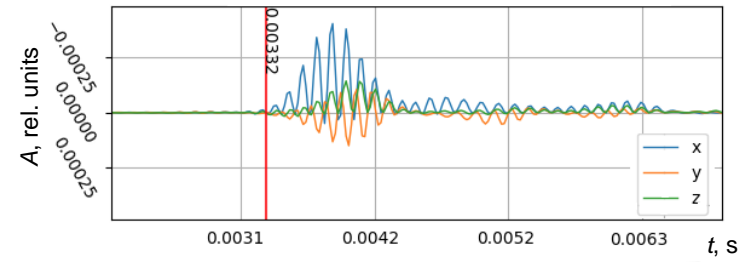

PULSE 2

LOCALIZATION RESULT

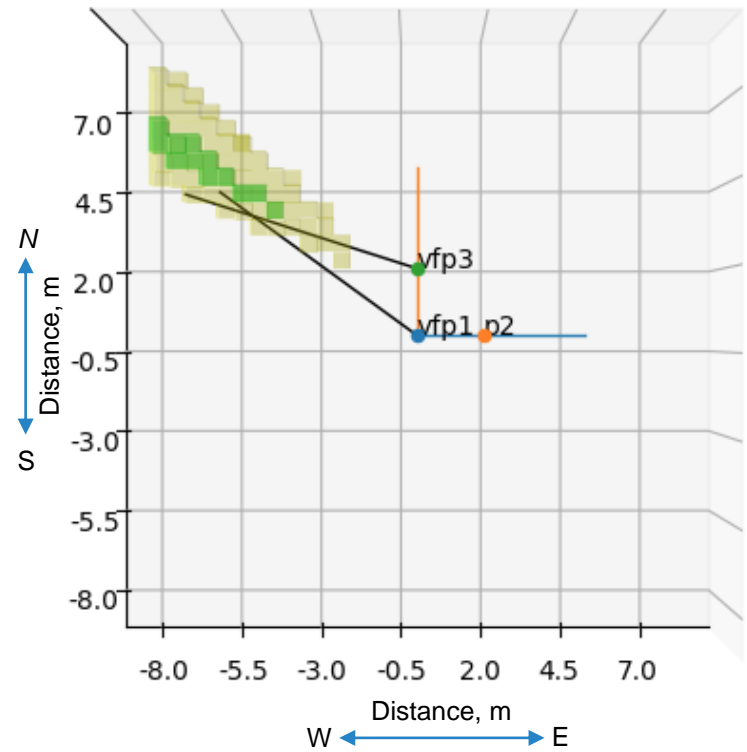
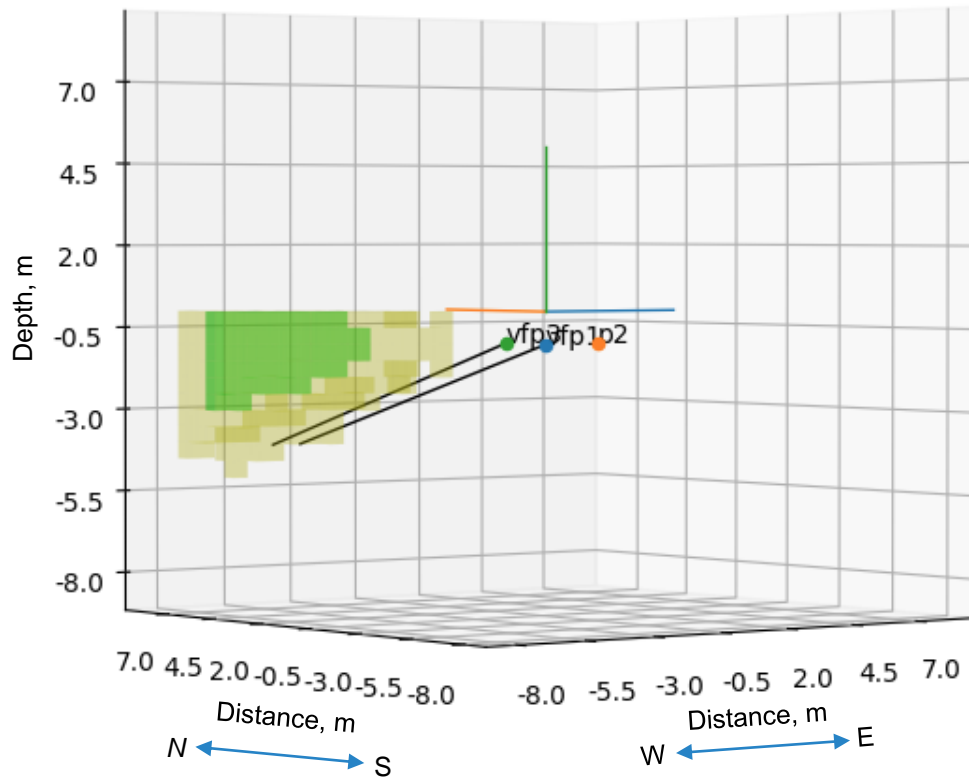

RESULTS: SOURCE DISTRIBUTION

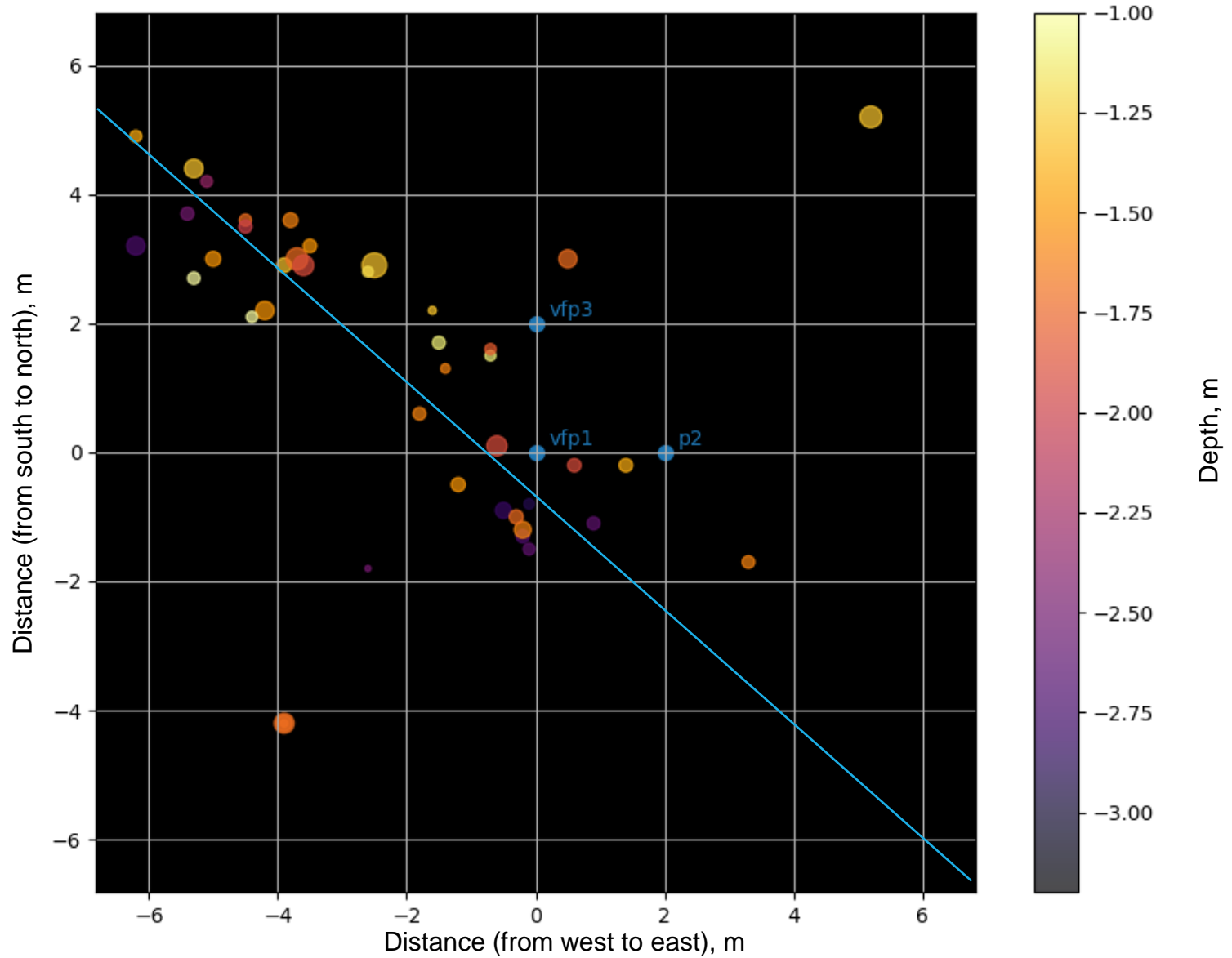

RESULTS: SOURCE DISTRIBUTION

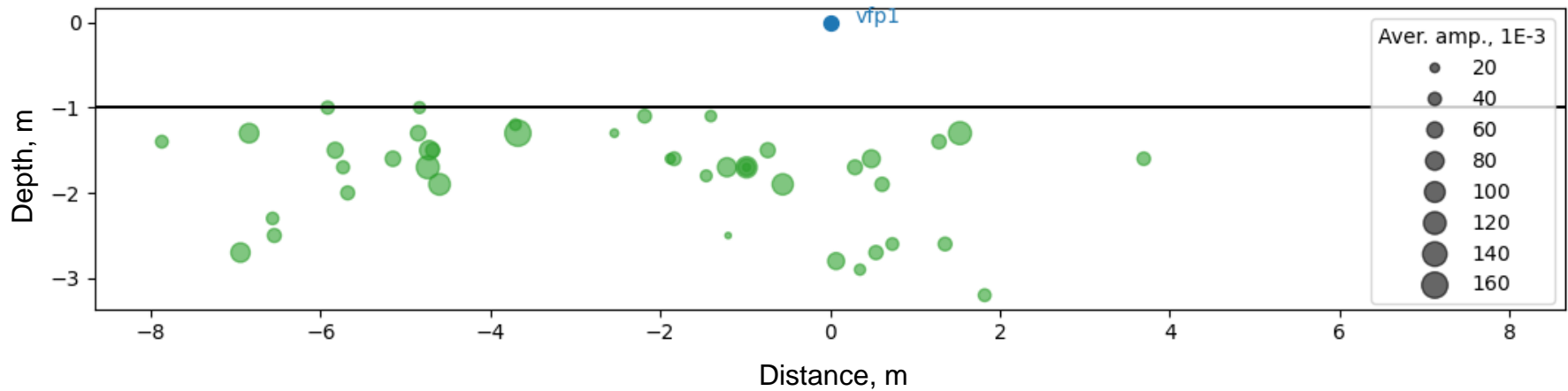

Duration of the record	105 minutes
------------------------	-------------

Number of pulses	43
------------------	----

Maximum depth	3.2 ± 0.25 m
---------------	------------------

Maximum distance	8 ± 0.25 m
------------------	----------------



Localization of acoustic emission sources according to the data of a distributed system of combined receivers

SHCHERBINA A.O., SOLODCHUK A.A., VASKIN V.A.,
TORGONSKYI V.E.